

Amana[®]

**Australian Top
Freezer
Refrigerator
Owner's Manual**

Keep these instructions for future reference. Be sure this manual stays with refrigerator.

Contents

Electrical Requirements	2
Model Identification	2
Installation Information	2
Space Requirements	2
Leveling Refrigerator	2
Door Removal	3
Door Reversal	3
Connect Ice Maker Water Supply Line	4
Installation Checklist	6
Controls	
Refrigerator and Freezer Controls	7
Exterior Moisture Control	7
Setting Controls	7
Refrigerator Features	
Refrigerator Shelves	7
Chiller Fresh™ System	7
Garden Fresh™ Crispers	8
Covered Storage Bucket	8
Dairy Center	8
Door Buckets	9
Door Shelves	9
Freezer Features	
Wire Shelf	9
Reversible Utility Rack	9
Care and Cleaning	
General	10
Odor Removal	10
Adhesives	10
Door Gaskets	10
Condenser Coils	10
Glass Shelves	11
Light Bulbs	11
Energy Tips	11
Vacation Tips	11
Normal Operating Sounds	12
Before Calling For Service	13
Warranty	14

Electrical Requirements

 **RECOGNIZE THIS SYMBOL AS A SAFETY PRECAUTION**

 **WARNING**

To avoid electrical shock which can cause severe personal injury or death, do not, under any circumstances cut or remove the round grounding prong from the plug. Refrigerator must be grounded at all times. Do not remove warning tag from power cord. Do not use a two-prong adapter. Do not use an extension cord.

This refrigerator is equipped with a three-prong (grounding) plug for protection against possible shock hazards. If a two-prong wall receptacle is encountered, contact a qualified electrician and have the two-prong wall receptacle replaced. Refrigerator must be earthed and connected to a separate 240 volt, 50 hz., 10A circuit.

Model Identification

Locate product information on the nameplate, found in upper left corner of refrigerator section. Record the following information:

Model Number _____
 Manufacturing Number _____
 Serial or S/N Number _____
 Date of purchase _____
 Dealer's name and address _____

Keep a copy of sales receipt for future reference.

Installation Information

A qualified engineer must connect refrigerator in accordance with these installation instructions. Measure door opening and depth and width of refrigerator. Remove handles or doors as required. Engineer must follow local electrical regulations.

Space Requirements

 **WARNING**

Keep flammable materials and vapors, such as gasoline, away from refrigerator. Failure to do so can result in death, explosion, fire, or burns.

- To ensure proper ventilation for your refrigerator, allow a 1" (2.5 cm) space at the top of refrigerator.
- If your refrigerator has an ice maker, make sure you allow extra space at the back for the water line connection. The refrigerator can be flush with the back wall if you do not have an ice maker installed.
- If you are installing refrigerator next to a fixed wall, leave 2 1/2" (6.5 cm) minimum on each side (depending on model) to allow the door to swing open 90°.

NOTE: Do not install the refrigerator near an oven, radiator, or other heat source, nor in a location where the temperature will fall below 55°F (13° C).

Leveling Refrigerator

 **CAUTION**

To avoid property damage, protect soft vinyl or other flooring with cardboard, rugs or other protective material when moving refrigerator. Make sure stabilizing leg is raised before moving refrigerator. Raise stabilizing leg by turning counterclockwise.

Some installations may require door reversal to achieve full door swing. If so proceed to *Door Reversal* section before leveling refrigerator.

If your refrigerator requires ice maker water supply connection, proceed to *Connect Ice Maker Water Supply* section before leveling refrigerator.

1. Plug in power cord.
2. Move refrigerator into final location.
3. Level refrigerator using a level placed on top of the refrigerator.
 - Remove toe grille. Remove bottom hinge cover if refrigerator has a stabilizing leg.
 - Turn $\frac{3}{8}$ " hex head roller adjustment screws to raise or lower refrigerator cabinet. Front of refrigerator must be $\frac{1}{4}$ " (6 mm), or $\frac{1}{2}$ bubble on level, higher than the back of refrigerator.
 - Make sure refrigerator cabinet is level from side to side by adjusting left and right roller adjustment screw. Turn stabilizing leg (some models) clockwise until firmly against floor.

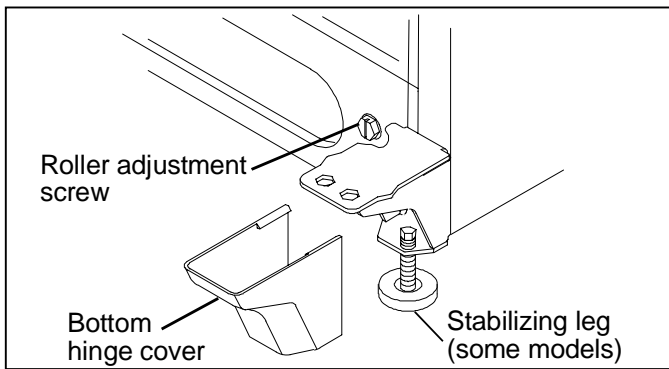

Door Removal

Some installations may require door removal for refrigerator to fit through door ways. If door removal is required perform steps 2–5 of *Door Reversal* section to remove doors. Perform steps 2–5 of *Door Reversal* section in reverse order to replace doors.

Door Reversal

Tools Required

Putty knife (blade covered with masking tape)
 $\frac{9}{32}$ " hex nut driver (some models)
 $\frac{3}{8}$ " hex nut driver
 Phillips screwdriver
 Blade screwdriver

Some installations require door reversal to achieve full door swing. To reverse door swing perform the following:

1. Remove and reverse refrigerator and freezer handles performing the following steps:

IMPORTANT: For plug removal requiring use of flat blade screwdriver or putty knife, **blade of tool must be covered with masking tape to avoid damage to refrigerator finish.** For plugs using a screwdriver- or nut driver- style head, use appropriate tool to avoid damage to plugs.

- Remove end caps from top (some models) and bottom of refrigerator door handle using a screwdriver with blade covered in masking tape. (See illustration following.) Remove one bottom and two top handle screws to remove handle.

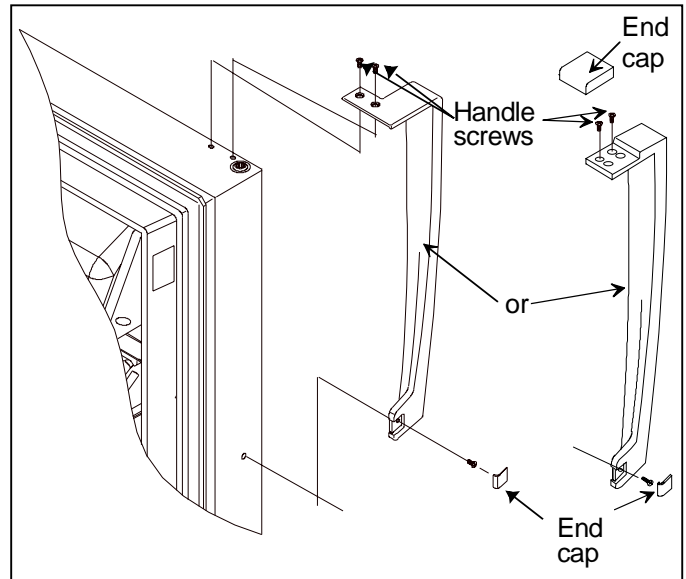

- **Models with automatically reversing logo.** Remove end cap from top of freezer handle using a screwdriver with the blade covered with masking tape. (See illustration below.) Remove one top and two bottom mounting screws.
- **Handles with removable logo on handle.** Remove screw caps from handles using a screwdriver with the blade covered in masking tape. Remove handle screws to remove freezer handle. Remove freezer handle cover by lifting end. Bend tabs behind nameplate up and remove nameplate. Rotate nameplate and cover.

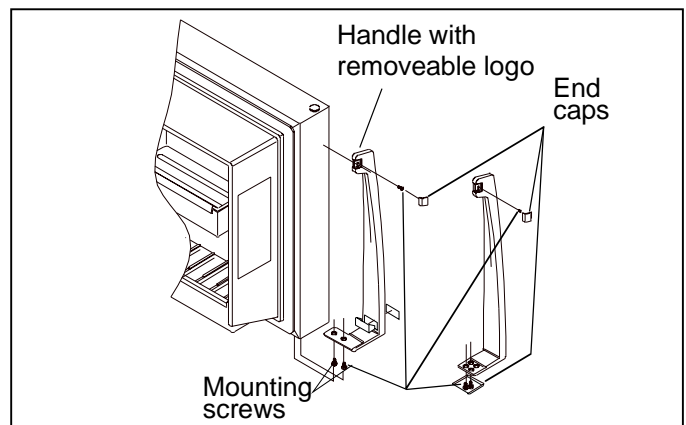

2. Remove top hinge cover. Top hinge cover snaps off. Remove top hinge and shim using hex nut driver.
3. Lift freezer door off center hinge.
4. Lift door closure off center hinge pin. Remove center hinge pin with a $\frac{5}{16}$ " or $\frac{9}{32}$ " hex nut driver.

5. Remove refrigerator door by lifting off bottom hinge.
6. Remove center hinge bracket and shim using Phillips screwdriver.
7. Remove toe grille and bottom hinge cover. Both snap off.
8. Remove bottom hinge and shim using hex nut driver.

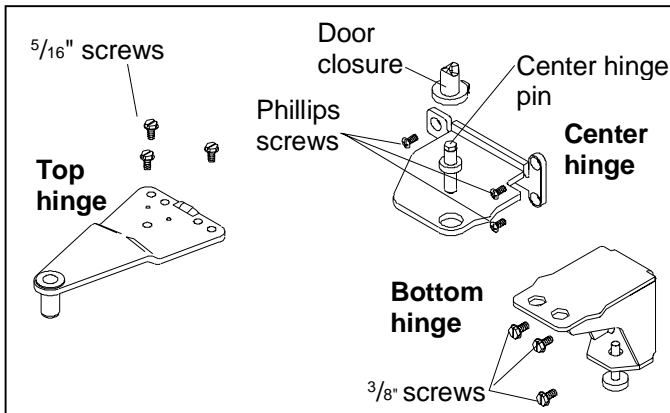

9. Reverse doors by performing the following steps:
 - Replace bottom hinge and shim on opposite side of cabinet.
 - Remove screws from center mullion. Place screws in holes left when center hinge bracket was removed. Rotate center hinge bracket 180° and install center hinge bracket on opposite side of cabinet with hinge screws. Reuse plastic hinge pin washers.
 - Place refrigerator door on bottom hinge. Install center hinge pin in center hinge bracket. Place door closure on center hinge pin.
 - Remove plugs from top of refrigerator cabinet. Replace plugs in holes left when top hinge was removed. Remove hinge hole cover from freezer door. Replace on opposite side of freezer door.
 - Place freezer door on center hinge and door closure. Install top hinge and shims on opposite side of cabinet using hex nut driver. Snap hinge cover in place on hinge.
 - Use a penny at top to space door 3/4" (19 mm) from cabinet. Make sure handle side of door is 1/8" (3 mm) higher than hinge side of door before tightening top hinge screws.

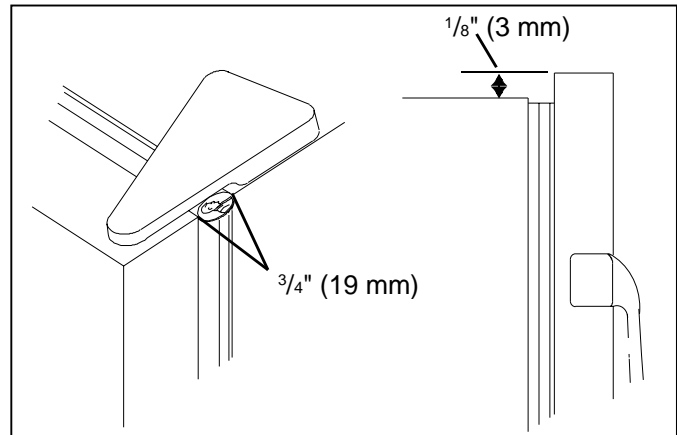

10. Remove plugs from side of refrigerator and freezer doors using a putty knife with the blade covered in masking tape.

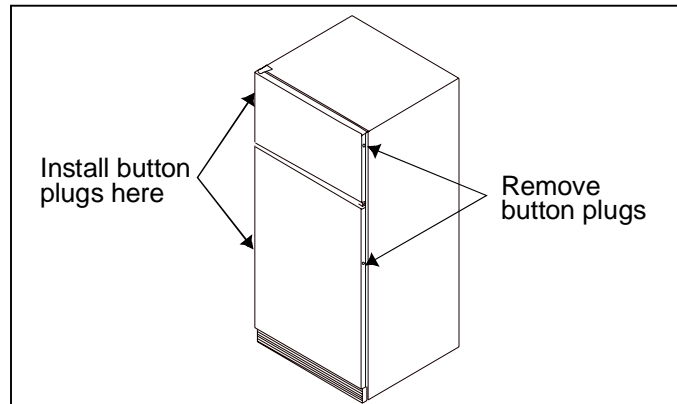

11. Mount freezer handle on opposite side of refrigerator door using mounting screws previously removed. Snap end cap(s) into place.
12. Mount refrigerator handle on opposite side of freezer door using mounting screws previously removed. Snap end cap(s) into place.
13. Replace plugs in empty side mounting holes on refrigerator doors.
14. Proceed to *Leveling Refrigerator* procedures for final placement of refrigerator.

Connect Ice Maker Water Supply Line

CAUTION

To avoid property damage, protect soft vinyl or other flooring with cardboard, rugs, or other protective materials when moving refrigerator. Make sure stabilizing leg is raised before moving refrigerator. Raise stabilizing leg by turning counterclockwise.



CAUTION

Observe the following to avoid property damage:

- Confirm water pressure to water valve is between 20 and 100 pounds per square inch.
- Copper supply tubing must be routed where the temperature is 55°F (13°C) or higher to prevent freeze-ups.
- Start adaptor fitting and nuts by hand to avoid cross threading. Tighten adaptor fitting and nuts with pliers and wrenches. Do not overtighten.
- Check for water leaks and correct if necessary before returning refrigerator to normal location, and 24 hours after connecting.

Important

- Before connecting water supply, contact a plumber to connect copper tubing to household plumbing in compliance with local codes and ordinances.
- DO NOT use self-piercing type or $\frac{3}{16}$ " saddle valves! Both reduce water flow, develop sediment build-up more rapidly, and may cause leaks if repair is attempted. The correct type of shut-off valve requires a $\frac{1}{4}$ " hole to be drilled on top or side (not bottom of horizontal pipe) of water supply pipe prior to valve attachment.

Materials Required

$\frac{1}{4}$ " O.D. (6 mm) flexible copper tubing. Length of copper tubing must reach from water supply connection to water valve inlet port on back of refrigerator plus an additional 8 ft. (2.5 m) of tubing for a service loop. A service loop will allow refrigerator to be pulled away from the wall without disconnecting tubing.

1. Remove plastic cap from water valve inlet port.

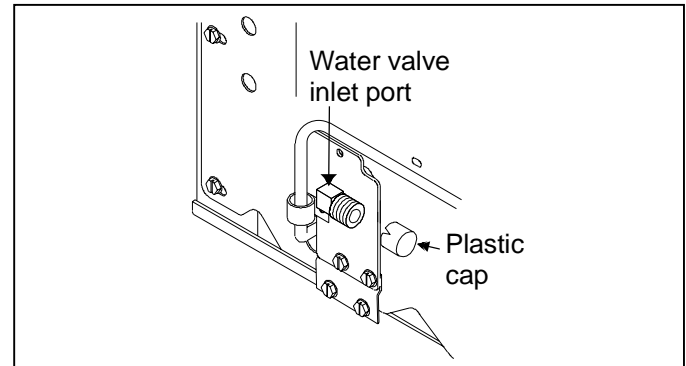

2. Place brass nut and brass sleeve on copper tubing. (Brass nut and sleeve are found in literature packet.) Insert copper tubing into water valve inlet port. Connect brass nut on copper tubing to water valve inlet port. Start connection by hand then use a $\frac{1}{2}$ " (13 mm) open end wrench. Make sure copper tubing is secure by pulling on copper tubing.

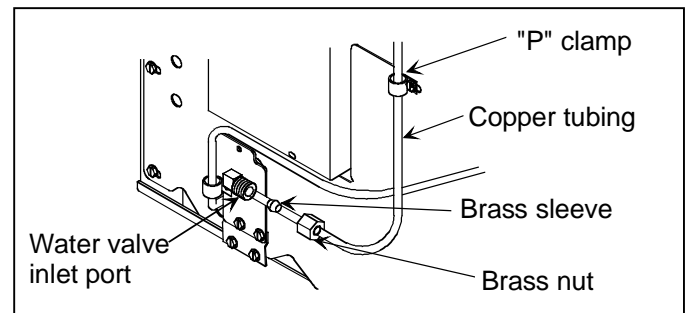

3. Turn on water supply to refrigerator and check for leaks. Correct any leaks at connection. Be careful not to overtighten connection.
4. Create a service loop using extreme care to avoid kinks. Secure copper tubing to refrigerator cabinet with a "P" clamp.
5. Proceed to *Leveling Refrigerator* for final refrigerator placement.
6. Review *Installation Checklist* in Owner's Manual with consumer.

Installation Checklist

This checklist is for personal records only.

Consumer Installer

Doors

- | | | |
|--------------------------|--------------------------|--|
| <input type="checkbox"/> | <input type="checkbox"/> | Handles are solidly attached to doors. |
| <input type="checkbox"/> | <input type="checkbox"/> | Handle side of door is 3 mm ($1/8$ ") higher than hinge side. (Door lowers when loaded with food.) |
| <input type="checkbox"/> | <input type="checkbox"/> | Doors seal completely to refrigerator cabinet. |

Leveling

- | | | |
|--------------------------|--------------------------|---|
| <input type="checkbox"/> | <input type="checkbox"/> | Refrigerator is tilted 6 mm ($1/4$ ") from front to rear. |
| <input type="checkbox"/> | <input type="checkbox"/> | Toe grille is properly attached to refrigerator. |

Ice Maker

- | | | |
|--------------------------|--------------------------|--|
| <input type="checkbox"/> | <input type="checkbox"/> | Water supply to refrigerator is turned on. |
| <input type="checkbox"/> | <input type="checkbox"/> | Water leaks are not present at connection between household water supply and refrigerator. (After 24 hours, consumer should check connection for water leaks.) |
| <input type="checkbox"/> | <input type="checkbox"/> | Ice maker arm is in on position for ice production. (It may take up to 24 hours for first harvest of ice.) |

Product Literature

- | | | |
|--------------------------|--------------------------|--|
| <input type="checkbox"/> | <input type="checkbox"/> | Owner's manual is reviewed including the following information. <ul style="list-style-type: none">• product registration card• Refrigerator and freezer controls• Chiller Fresh™ system• Garden Fresh™ crispers• normal operating sounds |
|--------------------------|--------------------------|--|

Notes _____

Consumer's Signature	Installer's Signature	Installer's Company Name/Phone Number	Date
----------------------	-----------------------	---------------------------------------	------

Controls

This refrigerator operates most efficiently at household temperatures of 13°–43°C (55°–110°F).

Refrigerator and Freezer Controls

Refrigerator and freezer controls are located on center divider between refrigerator and freezer sections.

When freezer control is set to *OFF*, neither refrigerator nor freezer sections will cool. Initially, set both controls to 4. Wait 24 hours for refrigerator and freezer sections to reach desired temperatures. After 24 hours, adjust controls, one number at a time, as desired. 1 is warmest setting and 7 is coldest.

Exterior Moisture Control

Exterior Moisture Control is located on center divider between refrigerator and freezer sections.

In humid conditions, refrigerators form condensation around doors. Special heaters in refrigerator cabinet minimize condensation.

Humidity depends on location of refrigerator. Set control to *ON* if refrigerator is in a humid area or whenever moisture is evident around doors. Set control to *OFF* if refrigerator is in a less humid area. Setting can be adjusted as conditions change.

High quality steel is used in this refrigerator. However, constant exposure to moisture may cause refrigerator cabinet to rust. Set control to *ON* anytime condensation forms on refrigerator cabinet.

Setting Controls

Set controls precisely with a household thermometer that includes temperatures between -21° to 10°C (-5° to 50°F).

Put thermometer snugly between frozen packages in freezer section. Wait 5–8 hours. If freezer temperature is not -18° to -16°C (0° to 2°F), adjust control, 1 number at a time. Check again after 5–8 hours.

Put thermometer in a glass of water in middle of refrigerator section. Wait 5–8 hours. If refrigerator temperature is not 3° to 4°C (38° to 40°F), adjust control, 1 number at a time. Check again after 5–8 hours.

Refrigerator Features

CAUTION

To avoid property damage, confirm shelf is secure before placing items on shelf.

Refrigerator Shelves

Models feature either glass or wire shelves. Shelves adjust to meet individual storage needs.

CAUTION

To avoid personal injury or property damage, handle tempered glass shelves carefully. Shelves may break suddenly if nicked, scratched, or exposed to sudden temperature change.

- Remove shelves by lifting front, releasing hooks from metal track then pulling out.
- Replace shelves by inserting hooks into metal track and lowering front.

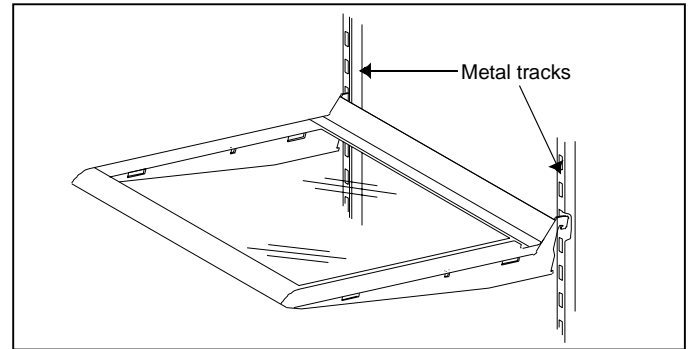

Chiller Fresh™ System

Chiller Fresh™ system features a drawer inside a sleeve. Air circulates between drawer and sleeve. This system keeps food fresh longer and up to 3°C (5°F) colder than refrigerator temperature.

Chiller Fresh™ control is located below front shelf trim. Control adjusts amount of air circulating around drawer. Slide control to *cold* for normal refrigerator temperature and to *coldest* for colder temperature. Ice crystals may form on drawer or food on *coldest* setting. Cold air can decrease refrigerator temperature. Refrigerator control may need to be adjusted.

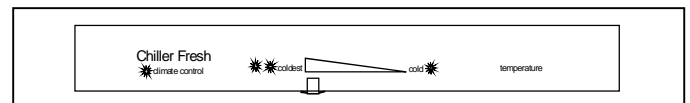

- Remove drawer by lifting and pulling out. Remove shelf by lifting front, releasing hooks from metal track then pulling out.
- Replace shelf by inserting hooks into metal track and lowering front. Use slots 1 through 3 only. Replace drawer by sliding in.

When moving Chiller Fresh™ system left or right, move control, located on center back wall of refrigerator section, to same side as system.

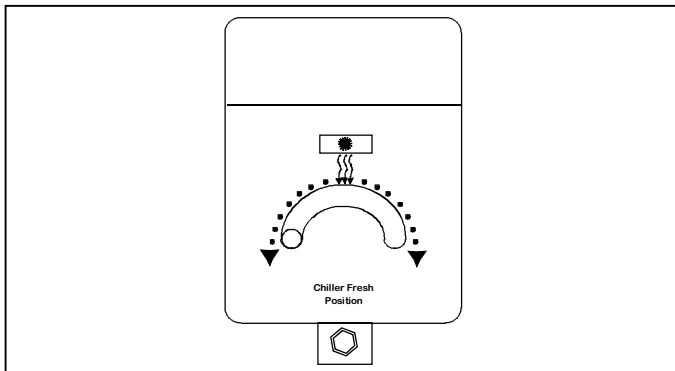

Garden Fresh™ Crispers

Garden Fresh™ crispers keep produce fresh longer. Wrap produce tightly. Do not wash produce before placing in crispers. Excess moisture could cause produce to spoil prematurely. Do not line crispers with paper towels. Paper towels will retain moisture.

Garden Fresh™ control is located below front shelf trim. Control adjusts humidity in crispers. Slide control to *high* for produce with leaves such as lettuce, spinach or cabbage. Slide control to *low* for produce with skins such as cauliflower, corn or tomatoes.

Remove shelf and crispers by completing the following steps.

1. Open left* crisper. *For doors hinged on left, open right crisper.

⚠ CAUTION

To avoid personal injury or property damage, handle tempered glass shelves carefully. Shelves may break suddenly if nicked, scratched, or exposed to sudden temperature change.

2. Remove shelf by gently pushing up from underneath. Tilt one end up then pull out.

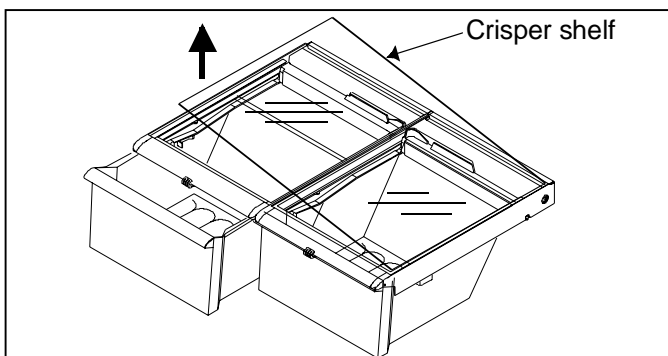

3. Remove left* crisper by lifting front while supporting

underneath then pulling out. *For doors hinged on left, remove right crisper.

4. Remove support post at recess in bottom center of refrigerator section.
5. Remove other crisper by sliding to opposite wall. Lift front while supporting underneath then pull out.
6. Replace crispers and shelf by reversing steps 1–5.

Covered Storage Bucket

Storage bucket has a lid and removable egg tray. When tray is removed, bucket will accept items such as a standard egg carton, ice, etc.

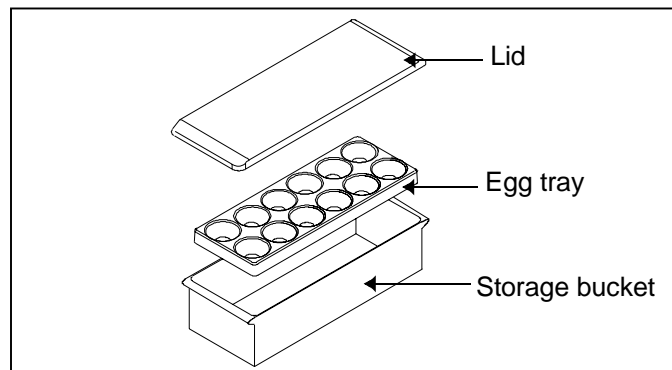

Dairy Center

Dairy center provides convenient storage for items such as butter, cheese, etc.

- Remove dairy center by lifting door, pushing tabs toward center and pulling out.
- Replace dairy center by sliding in until tabs lock into place and lowering door.

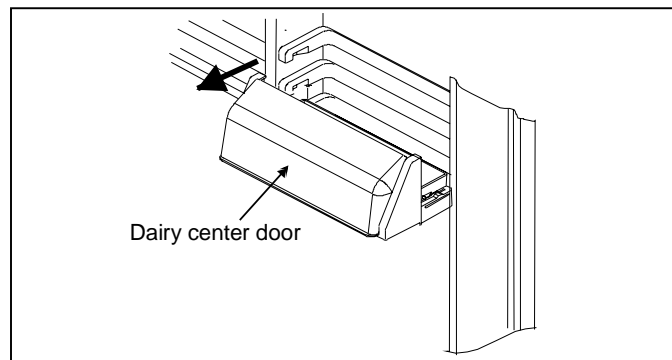

Freezer Features

Door Buckets

Door buckets adjust to meet individual storage needs.

- Remove door buckets by pushing tabs toward center and pulling out.
- Replace door buckets by sliding in until tabs lock into place.

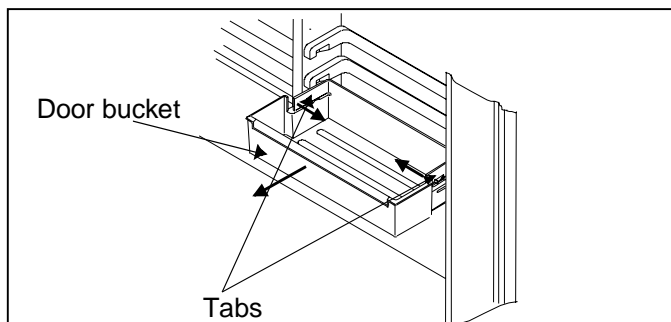

Door Shelves

- Remove door shelves by lifting ends and pulling out.
- Replace door shelves by placing shelf on glides and sliding down.

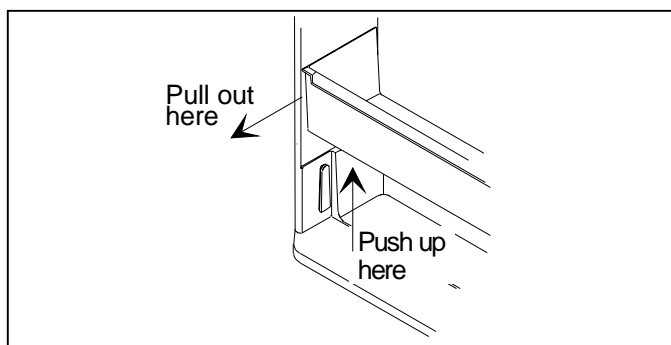

Wire Shelf

- Remove wire shelf by tilting one end up and pulling out.
- Replace wire shelf by tilting one end up and placing end on ledge. Tilt other end down and place on ledge.

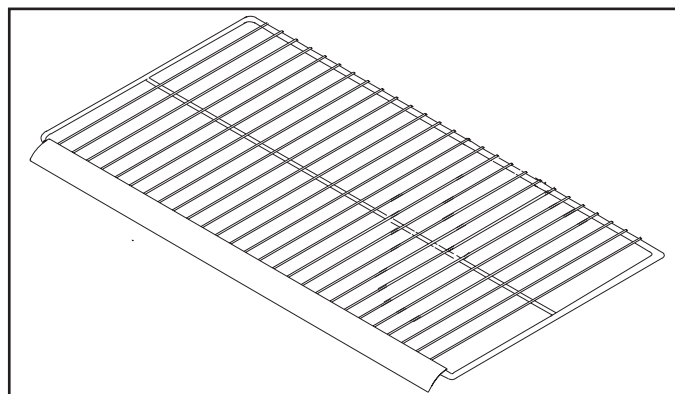

Reversible Utility Rack

Freezer utility rack provides extra storage for ice cube trays or other items. Remove rack by completing the following steps:

1. Locate hook of utility rack opposite of ball point joint. Holding wire rack firmly with both hands, press forward on hook with thumbs until utility rack detaches and swings loose.
2. Repeat pressure on the ball point hook until utility rack snaps free.

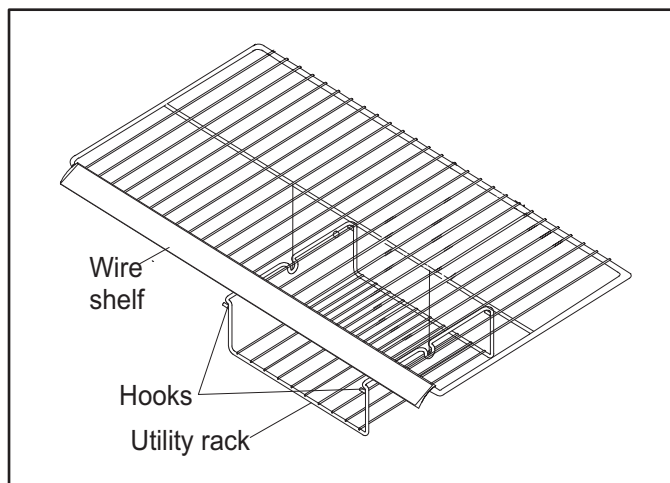

Care and Cleaning



CAUTION

To avoid electrical shock which can cause severe personal injury or death, disconnect power to refrigerator before cleaning. After cleaning, connect power.



CAUTION

To avoid personal injury or property damage, read and follow all cleaning product manufacturer's directions.

General

1. Wash surfaces with 4 tablespoons baking soda dissolved in 1 quart warm water and a soft, clean cloth.
 2. Rinse surfaces with warm water. Dry surfaces with a soft, clean cloth.
 - Do not use the following items:
 - abrasive or harsh cleaners, ammonia, chlorine bleach, etc.
 - concentrated detergents or solvents
 - metal scouring padsThese items can scratch, crack and discolor surfaces.
- Do not place buckets, shelves, etc. in dishwasher.

Odor Removal

1. Remove all food and disconnect power to refrigerator.
2. Clean all interior surfaces including ceiling, floor, and walls according to *General* instructions. Pay special attention to corners, crevices, and grooves. Include all drawers, shelves, and gaskets.
3. Connect power to refrigerator and return food to refrigerator. Wash and dry all bottles, containers and jars. Wrap foods in tightly sealed containers to prevent further odor. After 24 hours, check if odor was eliminated.

Complete the following steps if odor was not eliminated.

4. Complete steps 1–2.
5. Place Garden Fresh™ crispers on top shelf of refrigerator section. Pack refrigerator and freezer sections including doors with crumpled sheets of black and white newspaper.
6. Place charcoal briquettes randomly throughout newspaper.
7. Close doors and let stand 24–48 hours.
8. Remove charcoal briquettes and newspapers.
9. Complete steps 2–3.

Contact Consumer Affairs Department if odor was still not eliminated. Call **1-319-622-5511** outside U.S.A.

Adhesives

1. Remove glue residue by rubbing toothpaste into adhesive with fingers until adhesive loosens.
2. Rinse surface with warm water. Dry surface with a soft, clean cloth.

Door Gaskets

1. Clean door gaskets every 3 months (or as required to keep clean) according to *General* instructions.
2. Apply a light film of petroleum jelly to the hinge side of door to keep gaskets pliable.

Condenser Coils

Clean condenser coil every 3 months to ensure maximum performance of refrigerator. Accumulated dust and lint may cause the following:

- reduced cooling performance
 - increased energy usage
 - premature part failure
1. Remove toe grille by holding ends and pulling forward.
 2. Clean front surface of condenser coil with a vacuum cleaner hose nozzle.
 3. Replace toe grille by inserting clips in holes and snapping in.



CAUTION

To avoid property damage, protect soft vinyl or other flooring with cardboard, rugs, or other protective material. Verify stabilizing leg is raised before moving refrigerator. Raise stabilizing leg by turning counterclockwise.

4. Pull refrigerator away from wall. Run a vacuum brush across condenser fan outlet grille on back of refrigerator.

Glass Shelves



CAUTION

To avoid personal injury or property damage, handle tempered glass shelves carefully. Shelves may break suddenly if nicked, scratched, or exposed to sudden temperature change.

Remove shelf by lifting front, releasing hooks from metal track then pulling out. Place shelf on a towel. Allow shelf to adjust to room temperature before cleaning.

Clean crevices by completing the following steps:

1. Dilute mild detergent and brush solution into crevices using a plastic bristle brush. Let set for 5 minutes.
2. Spray warm water into crevices using faucet spray attachment.

3. Dry shelf thoroughly and replace shelf by inserting hooks into metal track and lowering front.

Light Bulbs



WARNING

To avoid electrical shock which can cause severe personal injury or death, disconnect power to refrigerator before replacing light bulb. After replacing light bulb, connect power.



CAUTION

To avoid personal injury or property damage, observe the following:

- Allow light bulb to cool.
 - Wear gloves when replacing light bulb.
1. Remove light bulb cover by removing screw at back center. Pull cover down. Replace bulb(s) with 40-watt appliance bulb(s).
 2. Replace light bulb cover by placing cover over light bulb. Insert and tighten screw.

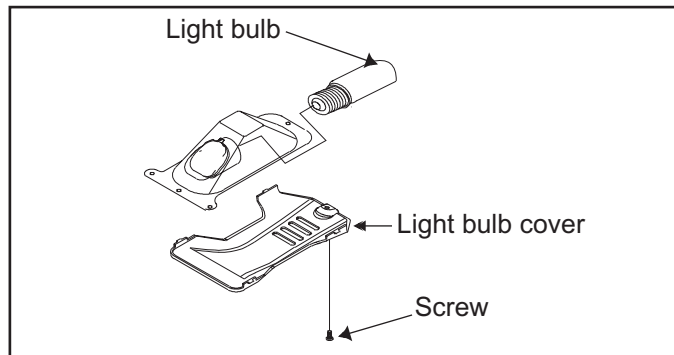

Energy Tips

This refrigerator is designed to be one of the most energy efficient refrigerators available. Reduce energy use by observing the following.

- Operate in normal household temperatures of 13° to 43°C (55° to 110°F) away from heat sources and direct sunlight.
- Set refrigerator, freezer, and Chiller Fresh™ system controls no colder than necessary.
- Keep freezer section full.
- Keep door gaskets clean and pliable. Replace gaskets if worn.
- Keep condenser coils clean.
- Turn exterior moisture control *ON* when necessary.

Vacation Tips

Complete the following steps for short vacations.

1. Remove perishable foods. **Warranty does not cover food loss.** Check warranty certificate for specific coverage.
2. If an ice maker is installed, move ice maker arm to off position.

Complete the following steps for long vacations.

1. Empty refrigerator and freezer sections.
2. Unplug refrigerator.
3. Clean refrigerator and door gaskets according to *General instructions in Care and Cleaning* section.
4. Prop doors open, so air can circulate inside.
5. If an ice maker is installed, turn water supply to refrigerator off and move ice maker arm to *off* position.

Normal Operating Sounds

This new refrigerator may be replacing a differently designed, less efficient or smaller refrigerator. Today's refrigerators have new features and are more energy efficient. As a result, certain sounds may be unfamiliar. These sounds are normal and will soon become familiar. These sounds also indicate refrigerator is operating and performing as designed.

1. **Freezer fan** air rushes and whirs.
2. **Sealed system** (evaporator and heat exchanger) refrigerant flow gurgles, pops or sounds like boiling water.
3. **Condenser fan** air rushes and whirs.
4. **Compressor** has a high pitched hum or pulsating sound.
5. **Defrost timer** sounds like an electric clock and snaps in and out of defrost cycle.
6. **Freezer control** clicks when starting or stopping compressor.
7. **Defrost heater** sizzles, hisses or pops.
8. **Ice cubes** from ice maker (some models) drop into ice bucket.

Water valve (some models) buzzes when ice maker fills with water. This occurs whether or not refrigerator is connected to water supply. If refrigerator is not connected to water supply, stop sound by raising ice maker arm to *off* position. (Not shown)

Foam insulation is very energy efficient and has excellent insulating capabilities. However, foam insulation is not as sound absorbent as previously used fiberglass insulation. (Not shown)

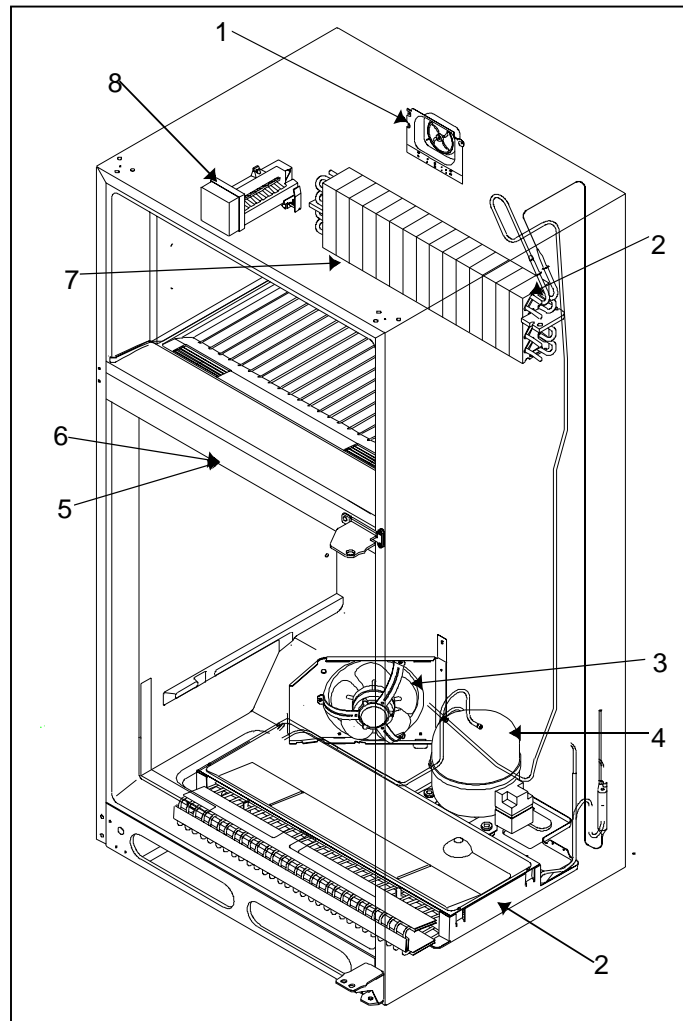

Before Calling For Service

Refrigerator does not operate.

- Confirm freezer control is on.
- Confirm refrigerator is plugged in.
- Check fuse or circuit breaker. Plug in another item at that wall outlet.
- Wait 40 minutes to see if refrigerator restarts. If freezer control is on, lights work but 2 fans and compressor are not operating, refrigerator may be in defrost cycle.

Refrigerator still won't operate.

- Unplug refrigerator. Transfer food to another unit or place dry ice in freezer section to preserve food.
Warranty does not cover food loss. Check warranty certificate for specific coverage.

Food temperature appears too warm.

- See above sections.
- Allow time for recently added warm food to reach refrigerator or freezer temperature.
- Check gaskets for proper seal.
- Clean condenser coils.
- Adjust refrigerator and/or freezer control.
- Confirm rear air grille is not blocked. Rear air grille is located behind left Garden Fresh™ crisper.

Chiller Fresh™ system temperature is too warm.

- Slide Chiller Fresh™ control to colder setting.
- Adjust freezer control to colder setting.

Food temperature is too cold.

- Clean condenser coils.
- Adjust refrigerator control.
- Adjust freezer control to warmer setting. Allow several hours for temperature to adjust.

Refrigerator runs too frequently.

- It may be normal to maintain constant temperature.
- Doors may have been opened frequently or for an extended period of time.
- Allow time for recently added warm food to reach refrigerator or freezer temperature.
- Clean condenser coils.
- Adjust freezer control.
- Check gaskets for proper seal.

Water droplets form on inside of refrigerator.

- It is normal during high humidity periods or if doors have been opened frequently.

Water droplets form on outside of refrigerator.

- Check door gaskets for proper seal.
- Turn exterior moisture control switch *ON*.

Garden Fresh™ crispers or Chiller Fresh™ system does not close freely.

- Check for a package which may prevent drawer from closing properly.
- Confirm drawer is in proper position.
- Clean drawer channels with warm, soapy water. Rinse and dry thoroughly.
- Apply a thin layer of petroleum jelly to drawer channels.
- Confirm refrigerator is level.

Refrigerator has an odor.

- See *Odor Removal* instructions in *Care and Cleaning* section.

Refrigerator or ice maker make unfamiliar sounds or seems too loud.

- It may be normal. See *Normal Operating Sounds* section.

Ice maker is not producing ice.

- Confirm ice maker arm is down.
- Confirm household water supply is reaching water valve.
- Confirm ice maker wiring harness is completely inserted into proper holes.
- Check for kinks in copper or plastic tubing. Remove kinks or replace tubing.
- Check electrical connections to water valve coil and connector block on refrigerator cabinet.
- Confirm freezer section is operating at proper temperature.

Ice cubes have an odor.

- See *Odor Removal* instructions in *Care and Cleaning* section.
- Discard ice and clean ice bucket or trays more frequently. Ice cubes are porous and absorb odors easily.

Ice cubes stick together or 'shrink'.

- Empty ice cube bucket or trays more frequently. If used infrequently, ice cubes may stick together or shrink.

Ice forms in inlet tube to ice maker.

- Check water pressure. Low water pressure will cause valve to leak. Self-piercing valves cause low water pressure. **Amana recommends using a saddle valve. Contact Kleenmaid for availability. Do not use self-piercing valve. Amana is not responsible for property damage due to improper installation or water connection.**

Warranty

For all appliances serviced in Australia, please refer to the following warranty:

AUSTRALIAN REFRIGERATION WARRANTY 5 YEAR PARTS AND LABOUR – TOTAL PRODUCT

DOMESTIC WARRANTY - FULL FIVE YEAR WARRANTY

In addition to all statutory rights which you, the Consumer, have under the relevant laws in respect of this appliance, during the first five years of ownership as the original purchaser of this Kleenmaid appliance, we guarantee that any fault caused by faulty material or workmanship becoming apparent will be rectified free of charge for parts and labour, provided that all service is performed during normal working hours by Kleenmaid or their designated Agents. Where the appliance is installed outside the normal servicing area of the above, the Purchaser must pay for the cost of transporting the appliance to and from the Agent or the Agent's travelling cost to and from the Purchaser's home.

COMMERCIAL WARRANTY - ONE YEAR WARRANTY

When this appliance is installed in a commercial application, you, the Consumer, have under the relevant laws in respect of this appliance, during your first one year of ownership as the original purchaser of the Kleenmaid appliance, we guarantee that any fault caused by faulty material or workmanship becoming apparent, will be rectified free of charge for parts and labour, provided that all service is performed during normal working hours by Kleenmaid or their designated Agents. Where the appliance is installed outside the normal servicing area of the above, the Purchaser must pay for the cost of transporting the appliance to and from the Agent or the Agent's travelling cost to and from the Purchaser's home.

WHAT THESE WARRANTIES DO NOT COVER

We are not responsible for any damage or malfunction unless caused by a defect in material or workmanship. This includes but is not limited to abuse, misuse, improper installation and transportation damage. We are not responsible for any consequential damages from any malfunction.

WARRANTY DOES NOT COVER REPLACEMENT OF LIGHT GLOBES OR GLASS BREAKAGE DUE TO IMPACT

In case of fractured glass do not use your appliance.

WARRANTY REGISTRATION

Please complete the enclosed warranty card and post it to us or phone our Customer Call Centre.

SERVICE ASSISTANCE

To assist you when phoning our Customer Call Centre number to arrange a service call please complete the following details and have them ready when you call.

Model Number: _____ Date of purchase: _____

Kleenmaid Store purchased from: _____ Date of installation: _____

**KLEENMAID CUSTOMER CALL CENTRE
CONTACT NUMBER
1 800 072 144**

Warranty

For all appliances serviced outside of Australia, please refer to the following warranty:

Limited One Year Warranty Limited Five Year Warranty on Compressor

First Year

Amana will provide a free replacement part, f.o.b. Amana, Iowa, U.S.A., for any part which is defective due to workmanship or materials.

Second through Fifth Years

Amana will provide a free replacement part, f.o.b. Amana, Iowa, U.S.A., for any compressor which is defective due to workmanship or materials.

Warranty Limitations

- Begins at date of original purchase.
- Service must be performed by an **authorized** Amana technician.

Warranty Is Void If

- Serial plate is defaced.
- Product is used on a commercial, rental or leased basis.
- Product has defect or damage due to product accident, alteration, connection to an improper electrical supply, fire, flood, lightning, shipping and handling, or other conditions beyond the control of Amana.
- Product is improperly installed or used.

Any questions regarding the above or to locate an authorized servicer, contact appliance supplier or:

Amana Appliances, L.C.

2800 220th Trail

PO Box 8901

Amana, IA 52204-0001

USA

Telephone 1-319-622-5511

Facsimilie 1-319-622-2180

Owner's Responsibilities

- Provide proof of purchase (sales receipt).
- Provide normal care and maintenance. Replace owner replaceable items where directions appear in Owner's Manual.
- Make product reasonably accessible for service.
- Pay premium service costs for service outside technician's normal business hours.
- Pay for service calls related to product installation or usage.

In no event shall Amana be liable for incidental or consequential damages including food loss*.

